

ORIGINAL PAPER

VALIDATION OF THE CZECH VERSION OF THE PERINATAL GRIEF SCALE

Kateřina Ratislavová¹, František Kalvas², Jiří Beran³¹ Department of Nursing and Midwifery, Faculty of Health Care Studies, University of West Bohemia in Pilsen, Czech Republic² Department of Sociology, Faculty of Philosophy, University of West Bohemia in Pilsen, Czech Republic³ Psychiatry Clinic, University Hospital in Pilsen, Czech Republic

Received September 29, 2014

Accepted November 7, 2014

Abstract

Aim: To translate the Perinatal Grief Scale questionnaire (short version) into the Czech language, assess its reliability and validate its use for measuring perinatal grief intensity in the Czech Republic. **Design:** A validation study. **Methods:** The Perinatal Grief Scale was, with the authors' consent, translated using the translation/back translation method. The focus group translation method was used for the final version of the translation. This version was tested on a group of 87 women who experienced perinatal loss in the Czech Republic between 2007 and 2013. The Czech short version of the Perinatal Grief Scale (CzSVPGS) was validated using exploration and confirmation factor analysis while its reliability was assessed using Cronbach's alpha coefficient. Psychosocial correlations of the CzSVPGS were assessed using the Pearson correlation coefficient. **Results:** We found that the CzSVPGS may be used as a single factor scale while maintaining all elements of the original scale. The unrotated solution of the exploration factor analysis estimated a strong factor (60.5% of total variance) that has a satisfactory burden in all 33 items. The reliability of this research tool as measured by Cronbach's alpha ($\alpha = 0.9545$) was high. **Conclusion:** We recommend that the CzSVPGS is used to objectivize grief intensity in women after perinatal loss and to identify high-risk women who are more vulnerable so that the healthcare system could help them.

Key words: Perinatal Grief Scale, perinatal loss, factor analysis, validation.**Introduction**

Grief and bereavement are natural conditions that follow the loss of someone/something that was valued highly by the individual. Bereavement is a multidimensional phenomenon that incorporates physical, behavioral and spiritual components. It is a characteristic complex of cognitive, emotional and social changes that follow the loss of a beloved person (Hollins Martin, Forrest, 2013; Stroebe et al., 2008). Such a beloved person can also be a fetus or a stillborn child. For every woman that has experienced miscarriage, stillbirth or the death of a newborn baby, the process of grieving is unique and specific. Understanding the grief of bereaved parents is very important for supportive professions in order to deliver adequate care and support (Hollins Martin, Forrest, 2013; Murray et al., 2000).

Several psychometric tools have been developed to measure the grief after perinatal loss: the Perinatal Grief Scale (PGS; Toedter et al., 1988), the Perinatal Bereavement Scale (PBS; Theut et al., 1989); the Munich Grief Scale (MGS; Beutel et al., 1995), the Perinatal Grief Intensity Scale (PGIS; Hutti et al., 1998), and the Perinatal Bereavement Grief Scale (PBGS; Ritsher and Neugebauer, 2002).

In particular, the Perinatal Grief Scale has demonstrated promise as an instrument that is able to identify women who are at risk for prolonged grief responses following reproductive loss (Adolfsson, 2011; Clauss, 2009; Neimeyer et al., 2008). Therefore we decided to confirm the usability of this scale in the Czech Republic, where there is no similar tool available to the researchers and healthcare professionals caring for bereaved parents.

Perinatal loss in the Czech Republic

The Czech Republic belongs among the post-communist countries of Central Europe. The political establishment between the years 1948 and 1989 did indeed influence the healthcare for mothers and

Corresponding author: Kateřina Ratislavová, Department of Nursing and Midwifery, Faculty of Health Care Studies, University of West Bohemia in Pilsen, nám. Odboje 18, Plzeň, Czech Republic, e-mail: ratislav@kos.zcu.cz

children. Among the major trends that influenced healthcare in the recent past were for instance: centralized care for pregnant women, hospitalized births, preventive care for pregnant women, creation of the perinatology centers that cared for high-risk pregnancies, continuous improvement of the hospitals with high-quality technical equipment, but dehumanization of healthcare, and a paternalistic approach to pregnant women, parents and mothers. The relatively high level of healthcare enabled the Czech Republic to become one of the countries with the lowest perinatal mortality rates in the world. In 1990 and 2000, the perinatal mortality rates were 9.9 and 4.4 per 1 000, respectively (Štembera, Velebil, 2003, p. 23).

Psychological care, however, lacked behind somatic care. Psychological care for women after perinatal loss was considered a taboo in the years before 1989; the trend generally encompassed everything related to death. Up until the end of the 20th century the approach towards bereaved mothers in hospitals involved getting rid of the dead fetus as fast as possible in the spirit of “like nothing ever happened”; rationalization and downplaying of the grief with the excuse that the baby would be healthy in the next pregnancy; limiting the medical dialog to medical and biological factors (sometimes the sex of the baby was not even communicated to the parent). Babies’ funerals were discouraged in order to avoid the “unnecessary stimulation” of grief.

The contemporary perinatal mortality in the Czech Republic is still very low. In 2011, when the limit for birth was still established by the weight of the fetus above 1 000 grams, the stillbirth rate according to the Czech statistical office was 2.91 per 1 000 and the total perinatal mortality was 4.01 per 1000 (Mother & Newborn 2011, ÚZIS). In 2012, the limit for abortion/birth was moved to the 22nd week of pregnancy and at least 500 grams of weight of the fetus. Because of that, the stillbirth rate increased to 3.48 per 1 000 and the total perinatal mortality was 5.48 per 1 000 (Mother & Newborn 2012, ÚZIS). The Czech Republic is, however, still coping with the insufficient psychological care for women after perinatal loss up to this day.

The Perinatal Grief Scale

The Perinatal Grief Scale (PGS) is a scale measuring the bereaved parents’ response to their loss (Lasker, Toedter, 1994, p. 47). The PGS was developed and validated in perinatal loss projects in Leigh Valley and Pennsylvania between 1984 and 1989. It was published in 1988 (Toedter et al., 1988). The analysis of the results led to the creation of a short version of the PGS (SVPGS) that included 33 items with an

alpha coefficient of 0.95 (Potvin et al., 1989). Even though the PGS was built on theoretical dimensions of grief, factor data analysis has shown three very different structures that were labelled as subscales: Active Grief, Difficulty Coping and Despair (Toedter et al., 1988; Toedter et al., 2001). The subscale Active Grief includes items that belong to the normal emotional reactions to the loss, such as sorrow, missing the child or crying. The subscale Difficulty Coping includes items that revolve around more complex emotional reactions and include the areas of social isolation, difficulty with normal life activities and with other people, lack of support, feelings of guilt and problems in marital relationships. It appears to indicate depression and withdrawal. The third subscale, Despair, encompasses long-term effects of the loss and strategies of coping with it. It involves existential feelings of helplessness and hopelessness.

There are 11 statements related to each subscale that the respondent evaluates on a 5-point Likert scale that is limited by the statements *completely agree* and *completely disagree* with a neutral central point. Each respondent can score a total minimum of 11 and maximum of 55 points on each subscale. The total score of the SVPGS varies between 33 and 165 points. Higher scores represent higher intensities of grief. Values above 91 points represent potential psychiatric morbidity. Toedter et al. (2001, p. 220) reported that 97.5% of people that took part in the research with SVPGS scored lower than 91 points.

The SVPGS was used in numerous studies in many countries around the world. Toedter et al. (2001) presented a comparison between 22 studies from 4 countries that utilized the scale with a total of 2 485 participants. According to the available information, the SVPGS has been translated into French, Spanish, German, Dutch, Swedish, Chinese and Thai (Adolfsson and Larsson, 2006; Beutel et al., 1992; Capitulo et al., 2010; Toedter et al., 2001; Yan et al., 2010). High levels of internal consistency, reliability as well as construct and convergent validity were confirmed across the studies, types of loss and languages. Cronbach’s alpha for the whole SVPGS is 0.92 to 0.96; the subscale coefficients are 0.92 for Active Grief, 0.89 for Difficulty Coping, and 0.88 for Despair (Toedter et al., 2001, p. 214). The researchers utilized the SVPGS mainly to assess the grief of women and men following the perinatal loss experience such as miscarriage, stillbirth, ectopic pregnancy, newborn death, diagnosis of fetal anomalies, abortion, and placement for adoption.

We are convinced that if the healthcare professionals in the Czech Republic were able to use a tool such as

the SVPGS to assess the state of parents after perinatal loss, it could help them to better understand the grief of the bereaved parents and increase the quality of psychosocial care for them.

Aim

The objectives were to (a) create the Czech version of the SVPGS (CzSVPGS); (b) examine the factor structure of the CzSVPGS; (c) find similarities and differences in the factor structure between the CzSVPGS and other studies; (d) examine the psychometric properties of the CzSVPGS; and (e) identify the psychosocial correlates of the CzSVPGS.

Methods

Design

The validation study was initiated with the translation of the original English version of the SVPGS. The authors consented to its translation into the Czech language and its use in the Czech Republic. For the purpose of translation, the “translation/back translation” and “focus group translation” methods were used (Capitulo et al., 2001, p. 167). The translation of the SVPGS from English to Czech was done by a professional translator and the back translation from Czech to English was done by another professional translator. The discussion about the translated material and semantic analysis of the text was led using the focus group method. The group consisted of bilingual individuals with experience in the English language as well as psychology and midwifery; a native speaker was also present (United Kingdom). The goal of the translation was to create an instrument that maintains the meaning of each statement in the Czech language with its corresponding English equivalent and can be understood by women in the Czech Republic. During the translation of the Likert scale, the neutral middle point was modified from *neither agree nor disagree* to *I don't know* because it corresponds better with the meaning and habitual use in the Czech language.

Sample

The sample consisted of 87 women who suffered from perinatal loss (stillbirth or early neonatal death) in the Czech Republic between the years 2007 and 2013. The majority of the respondents were in contact with an online discussion group or with a self-help group of parents after perinatal loss.

Data collection

Initially, a pilot study was conducted and 10 women completed the CzSVPGS during personal meetings. The comprehensiveness of the statements was confirmed. We used the CzSVPGS questionnaire

together with a questionnaire on intervention after perinatal loss, which was created by researchers and provided information about demographics and the interventions women participated in after perinatal loss (physical contact with the child, mementos). Both questionnaires were emailed to women who experienced perinatal loss. The Dlouhá Cesta (Long Way) organization's project Prázdná kolébka (Empty Crib) served as a communication channel through which the women were targeted and asked to participate in a quantitative survey. At the same time, the organization posted about this opportunity on their website using a letter of motivation and a link to the online questionnaire. Considering the relatively small sample pool and the sensitive topic, only the following criteria were chosen to pick potential participants: woman, experience with perinatal loss in the Czech Republic, maximum of five years elapsed from the perinatal loss, and Czech nationality. The research took place between January 2011 and April 2013.

Data analysis

Firstly, we investigated whether our data set was suitable for factor analysis. We used the Kaiser–Meyer–Olkin measure (KMO) to assess data suitability, where the KMO value should be higher than 0.6. The KMO value of our data set was meritorious (0.88; StataCorp 2013).

Secondly, we made confirmatory factor analysis (CFA) of the SVPGS's factor structure proposed by previous studies (Capitulo et al., 2010; Potvin et al., 1989; Yan et al., 2010). Cronbach's alpha of the whole scale and subscales from these studies are reported.

Thirdly, we carried out our own exploratory factor analysis (EFA) using maximum likelihood and varimax rotation. Because we wanted to bring the solution as close as possible to the previous studies (ibid.) we forced EFA to extract three factors. We also report Cronbach's alpha of our subscales.

Fourthly, we established two structural equation models (SEM) on our EFA results. The first one had all paths with loadings above 0.35 included. The second one also included only paths with loadings above 0.35, but if the item was connected with two factors, the connection with the weaker loading was omitted. Both models were compared regarding the comparative fit index (CFI), the root mean square error of approximation (RMSEA), the chi-squared test, and the Bayesian information criterion (BIC).

Fifthly, we showed that regarding the results of the CFA and SEM, the CzSVPGS is an accurate tool. We used the results from unrotated EFA as evidence.

Finally, we researched the psychosocial correlations of the CzSVPGS survey results with known groups (women who visited a psychiatrist and women segmented by time elapsed from the perinatal loss).

Results

Sample

The sample consisted of 87 women after perinatal loss in the Czech Republic. Their average age was 33 years and the average time elapsed from the loss was 2.2 years. In our sample, 78% of women experienced stillbirth and 22% of women experienced early neonatal death. In 16.1% of the cases, the women saw their baby after perinatal loss, 25.3% saw and held the baby (41.4% saw the baby in all) and 58.6% of women did not see or hold the baby. In 24.1% of cases, the women owned a memento of their child.

Confirmatory factor analysis (CFA)

For testing the factor structure of the SVPGS, Yan et al. (2010, p. 158) suggest to use “confirmatory factor analysis (CFA) with maximum likelihood estimation”. For testing the goodness of fit, they suggest to use “comparative fit index (CFI) and the root mean square error of approximation (RMSEA) ... CFI above 0.9 and RMSEA below 0.8 would indicate an acceptable fit” (ibid.). None of the previous solutions had an acceptable fit in our data. Classical solution (e.g. Potvin, et al., 1989): CFI = 0.779, RMSEA = 0.092; solution of Yan et al. (2010): CFI = 0.826, RMSEA = 0.093; solution of Capitulo et al. (2010): CFI = 0.798, RMSEA = 0.109). That is why we started our analysis with exploratory factor analysis.

Exploratory factor analysis (EFA)

Our EFA extracted 4 factors with eigenvalue higher than 1.0. The first factor, the strongest one, accounted for 60.52% of the variance before rotation. The weaker factors accounted, also before rotation, for 7.74%, 5.41%, and 4.71%. The four factor structure was very hard to interpret either before or after varimax rotation. We were also looking for a solution as close as possible to Potvin, Lasker and Toedter (1989). That is why we left the four factor solution and we forced exploratory factor analysis to use only the first three strongest factors and apply varimax rotation on them. Still, our best solution is not as symmetric as that by Potvin et al. (1989). All factor loadings for all three factors are shown in Table 1. The restructured solution is shown in Table 2. In this table we are reporting only factor loadings higher than 0.35 which we consider sufficiently conservative. There is only one item which on all

three factors has loadings lower than 0.35 (no. 5, “I feel a need to talk about the baby”).

Our “introducing” solution from ETA (with all paths among factors and items with loadings above 0.35) has quite good scores in CFA (CFI = 0.858; RMSEA = 0.077); CFI is slightly below 0.9 and RMSEA is far below 0.8. When we leave only paths with the strongest loading for each item in the model (i.e. in cases of items with paths from two factors we polish out the weaker path) and we test the model through CFA, we receive mixed results (see Table 3). The CFI and RMSEA of the “polished” model are only very slightly worse (by 0.02 and 0.004, respectively), the “introducing” model is closer to a saturated model from the chi-squared point of view (difference of chi-squared = 43.6, df = 11, $p < 0.001$), but the “polished” model is much more parsimonious (BIC of the “introducing” model is bigger by 5.6). But still, both models have better CFI and RMSEA than solutions suggested by previous studies (Potvin et al., 1989; Yan et al., 2010; Capitulo et al., 2010).

We favored the parsimony and ease of interpretation of the “polished” model. This model consists of 32 items (F1: 6; F2: 23; F3: 3). Here are schemas of our two structural models: Schema 1 is the original “introducing” solution from our ETA, and Schema 2 is the “polished” model, that is, the final one. The factor structure of the “polished” model consists of three factors; we named them Active Grief, Difficulty Coping/Despair, and Guilt. Factor 1 (Active Grief) correlates most strongly with 6 items with a loading higher than 0.35, Factor 2 (Difficulty Coping/Despair) with 23 items, and Factor 3 (Guilt) with 3 items. As stated above, one item does not correlate sufficiently with any factor. The new subscales have alpha coefficients as follows: Active Grief 0.84, Difficulty Coping/Despair 0.95, and Guilt 0.81.

The new structure has one dominant Factor 2 (Difficulty Coping/Despair) which contains all 11 items of the original subscale Difficulty Coping, but also contains 8 items of the original subscale Despair and 4 items of the original subscale Active Grief. All significant loadings are in the range from 0.3692 to 0.7995. Factor 1 (Active Grief) consists of 5 items from the original subscale Active Grief. Factor 1 also includes 1 item of the original subscale Despair which has the highest loading on it. All significant loadings are in the range from 0.5144 to 0.7310. Factor 3 (Guilt) correlates with 1 item of the original subscale Active Grief and 2 items of the original subscale Despair. All significant loadings are in the range from 0.6431 to 0.7697.

Table 1 Factor loadings for all three factors of the CzSVPGS

Item (n = 33, α = 0.9545)		Factor 1	Factor2	Factor3
Active grief (n = 11, α = 0.8666)				
1.	I feel depressed.	0.4381	0.4653	0.1462
3.	I feel empty inside.	0.4516	0.4997	0.2031
5.	I feel a need to talk about the baby.	0.1987	0.2312	0.2237
6.	I am grieving for the baby.	0.6580	0.1901	0.1825
7.	I am frightened.	0.2824	0.2011	0.6431
10.	I very much miss the baby.	0.6241	0.3103	0.1210
12.	It is painful to recall memories of the loss.	0.5933	0.2215	0.1122
13.	I get upset when I think about the baby.	0.5826	0.2352	0.3526
14.	I cry when I think about him/her.	0.7310	0.1852	0.2122
19.	Time passes so slowly since the baby died.	0.3821	0.4829	0.2495
27.	I feel so lonely since he/she died.	0.2969	0.7719	0.0684
Difficulty coping (n = 11, α = 0.9024)				
2.	I find it hard to get along with certain people.	0.1378	0.3961	0.3147
4.	I can't keep up with my normal activities.	0.2862	0.5430	0.4477
8.	I have considered suicide since the loss.	0.0291	0.6291	0.2994
11.	I feel I have adjusted well to the loss.	0.2821	0.3824	0.0168
21.	I have let people down since the baby died.	0.2807	0.6925	0.1361
24.	I get cross at my friends and relatives more than I should.	0.0284	0.5044	0.2209
25.	Sometimes I feel like I need a professional counsellor to help me get my life back together again.	0.4614	0.6117	0.1372
26.	I feel as though I am just existing and not really living since he/she died.	0.3803	0.7995	0.1646
28.	I feel somewhat apart and remote, even among friends.	0.2116	0.7669	0.0795
30.	I find it difficult to make decisions since the baby died.	0.1441	0.7318	0.3413
33.	It feels great to be alive.	0.1069	0.6901	0.2728
Despair (n = 11, α = 0.8837)				
9.	I take medicine for my nerves.	0.0876	0.3692	0.1559
15.	I feel guilty when I think about the baby.	0.2979	0.2021	0.6868
16.	I feel physically ill when I think about the baby.	0.5144	0.4090	0.2752
17.	I feel unprotected in a dangerous world since he/she died.	0.2021	0.4222	0.3548
18.	I try to laugh, but nothing seems funny anymore.	0.3478	0.6300	0.3306
20.	The best part of me died with the baby.	0.2183	0.6858	0.2315
22.	I feel worthless since he/she died.	0.1464	0.6746	0.4509
23.	I blame myself for the baby's death.	0.1513	0.3186	0.7697
29.	It's safer not to love.	-0.0597	0.5714	0.3000
31.	I worry about what my future will be like.	0.1176	0.5810	0.3549
32.	Being a bereaved parent means being a "second-class citizen".	0.1440	0.4948	0.2523
Accounted variance (%)		18.56	39.64	15.48

We favored the parsimony and ease of interpretation of the "polished" model. This model consists of 32 items (F1: 6; F2: 23; F3: 3). Here are schemas of our two structural models: Schema 1 is the original "introducing" solution from our ETA, and Schema 2 is the "polished" model, that is, the final one. The factor structure of the "polished" model consists of three factors; we named them Active Grief, Difficulty Coping/Despair, and Guilt. Factor 1 (Active Grief) correlates most strongly with 6 items with a loading higher than 0.35, Factor 2 (Difficulty Coping/Despair) with 23 items, and Factor 3 (Guilt) with 3 items. As stated above, one item does not correlate sufficiently with any factor. The new subscales have alpha coefficients as follows: Active Grief 0.84, Difficulty Coping/Despair 0.95, and Guilt 0.81.

The new structure has one dominant Factor 2 (Difficulty Coping/Despair) which contains all 11 items of the original subscale Difficulty Coping, but also contains 8 items of the original subscale Despair and 4 items of the original subscale Active Grief. All significant loadings are in the range from 0.3692 to 0.7995. Factor 1 (Active Grief) consists of 5 items from the original subscale Active Grief. Factor 1 also includes 1 item of the original subscale Despair which has the highest loading on it. All significant loadings are in the range from 0.5144 to 0.7310. Factor 3 (Guilt) correlates with 1 item of the original subscale Active Grief and 2 items of the original subscale Despair. All significant loadings are in the range from 0.6431 to 0.7697.

Table 2 Factor loadings for new three factors of the CzSVPGS

Item (n = 32, $\alpha = 0.9549$)	Factor 1	Factor2	Factor3
Factor 1			
Active Grief (n = 6, $\alpha = 0.8378$)			
6. I am grieving for the baby.	0.6580		
10. I very much miss the baby.	0.6241		
12. It is painful to recall memories of the loss.	0.5933		
13. I get upset when I think about the baby.	0.5826		
14. I cry when I think about him/her.	0.7310		
16. I feel physically ill when I think about the baby.	0.5144		
Factor 2			
Difficulty coping/ Despair (n = 23, $\alpha = 0.9474$)			
1. I feel depressed.		0.4653	
3. I feel empty inside.		0.4997	
19. Time passes so slowly since the baby died.		0.4829	
25. Sometimes I feel like I need a professional counsellor to help me get my life back together again.		0.6117	
26. I feel as though I am just existing and not really living since he/she died.		0.7995	
2. I find it hard to get along with certain people.		0.3961	
8. I have considered suicide since the loss.		0.6291	
9. I take medicine for my nerves.		0.3692	
11. I feel I have adjusted well to the loss.		0.3824	
18. I try to laugh, but nothing seems funny anymore.		0.6300	
20. The best part of me died with the baby.		0.6858	
21. I have let people down since the baby died.		0.6925	
24. I get cross at my friends and relatives more than I should.		0.5044	
27. I feel so lonely since he/she died.		0.7719	
28. I feel somewhat apart and remote, even among friends.		0.7669	
29. It's safer not to love.		0.5714	
30. I find it difficult to make decisions since the baby died.		0.7318	
32. Being a bereaved parent means being a "second-class citizen".		0.4948	
33. It feels great to be alive.		0.6901	
4. I can't keep up with my normal activities.		0.5430	
17. I feel unprotected in a dangerous world since he/she died.		0.4222	
22. I feel worthless since he/she died.		0.6746	
31. I worry about what my future will be like.		0.5810	
Factor 3			
Guilt (n = 3, $\alpha = 0.8114$)			
7. I am frightened.			0.6431
15. I feel guilty when I think about the baby.			0.6868
23. I blame myself for the baby's death.			0.7697
Not included			
5. I feel a need to talk about the baby.			
Accounted variance (%)	18.56	39.64	15.48

Note: We present only the highest loading of each item and we also suppress loadings below 0.35.

Table 3 Comparison of the CzSVPGS's structural models

Model	CFI	RMSEA	BIC	Difference: saturated vs. model		
				chi-squared	df	p
M1: "introducing"	0.858	0.077	8330.6	681.8	450	<0.001
M2: "polished"	0.838	0.081	8325.0	725.4	461	<0.001
M1 – M2	---	---	5.6	43.6	11	<0.001

All our SEMs reveal unsatisfactory similarity of their inner structure to the inner structure of models from previous studies. The best solution we receive after varimax rotation has one strong factor with 23 items (out of 33!) and for two other factors here are only 9 remaining items. Items grouped under the roofs of the

two small factors are also specific, neither with marginal meaning nor mainstream (painful memories, guilty feelings, etc.). One could wonder if the CzSVPGS is functional at all. We think that the CzSVPGS functions on the whole as one unstructured scale. Cronbach's alpha of the whole

scale is very satisfactory (0.9545). When we run unrotated EFA, it estimates one very strong factor (60.5% of accounted variance) with eigenvalue far bigger than eigenvalue of the second strongest factor (13.5 vs. 1.7). This very strong factor has satisfactory loadings on all 33 items, the smallest on item no. 5 (0.3667) and the biggest on item no. 26 (0.8679); in case of all items, this strongest factor has bigger loadings than all other estimated factors. The solution

with one strong factor has a lower log likelihood (-441.2871) than all other solutions and the lowest value of BIC (1029.949) as well. It reveals that the unrotated one factor solution is the most parsimonious one and well suited for the description of the CzSVPGS structure. We remind that the overall value of KMO is the meritorious one (0.8821).

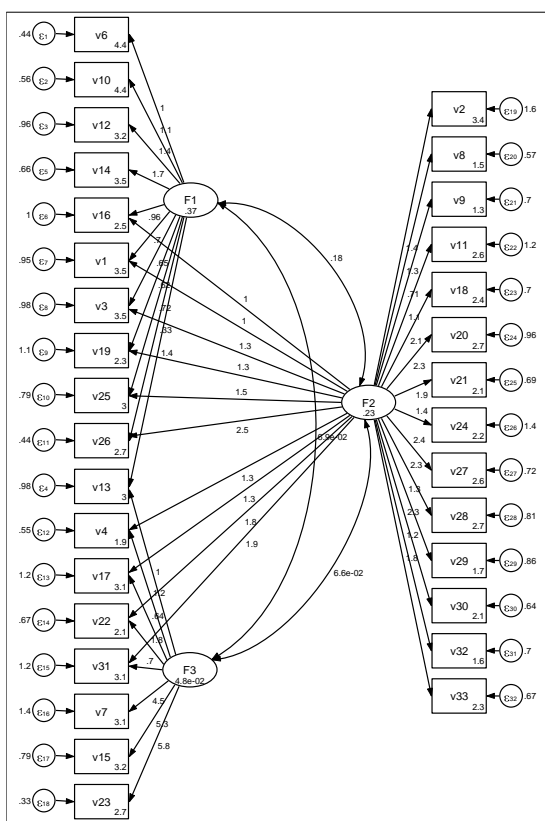

CFI = 0,858; RMSEA = 0,077
Schema 1 “introducing” solution

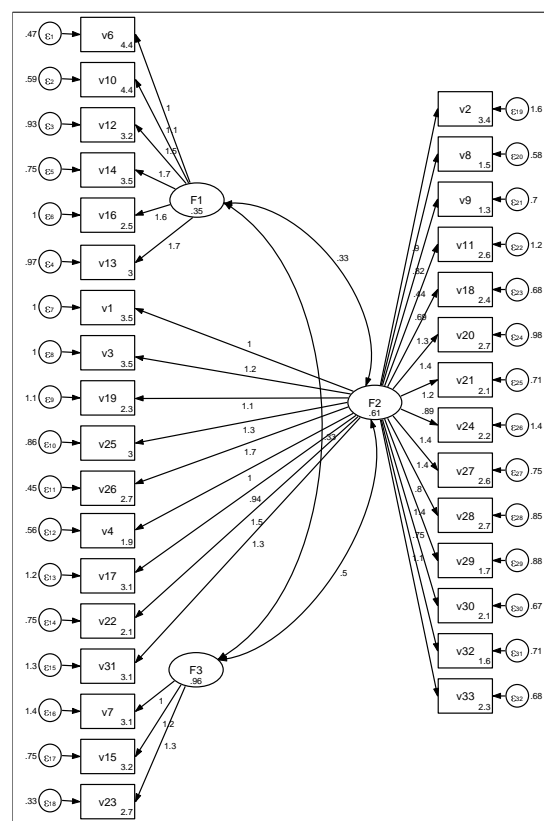

CFI = 0,838; RMSEA = 0,077
Schema 2 “polished” solution

Similarities and dissimilarities in the factor structure between the CzSVPGS and other studies

Studies on the SVPGS published before 2000 were very conclusive; they brought evidence about all items’ reliability and their stable place in the SVPGS. Our study is consistent with these findings. Reliability test by Cronbach’s alpha, exploratory and confirmatory factor analyses all show stable existence of perinatal grief that can be measured by SVPGS. But our findings show a different structure of the SVPGS. Previous studies were consistent in finding three factors, each correlating with 11 items of the SVPGS. We found one dominant factor (Factor 2) which almost seems like a combination of two original subscales, Difficulty Coping and Despair. We also found two minor factors, Factor 1, mainly established on items from the original subscale

Active Grief, and Factor 3 consisting of several items from all three original subscales; all these items were connected with guilt. It seems that the best is the unrotated solution with only one strong factor.

Studies published after 2000 (Capitulo et al., 2010; Yan et al., 2010) also showed different structuring of the SVPGS. Capitulo et al. (2010) extracted two factors; the first replicated the original SVPGS Active Grief substructure, and the second combined two original subscales Difficulty Coping and Despair. At first sight, it looks very similar to our Factor 1 and Factor 2. But their study rejected 14 out of 33 original items; it means that they fully replicated the Active Grief subscale (contrary to us), and while from the original subscales Despair and Difficulty Coping, we used almost all items, they did not.

Our factor structure highlighted the combination of the Difficulty Coping and Despair subscales (Capitulo et al., 2010) and replication of the Active Grief subscale. A study by Beutel et al. (1992) also replicated the original Active Grief subscale and offered a new solution for the other original subscales. But the offered solution was different from that by Capitulo et al. (2010).

A study by Yan et al. (2010) from Hong Kong also presented a structure different from the original SVPGS subscales. It also differs from our solution; items which correlate with our Factor 2 are parts of two subscales in the Hong Kong study, Sense of Worthlessness and Social Detachment. The last subscale in the study, Painful Recollection, contains only items correlated with our Factor 1, but not all items correlating with our Factor 1 are part of the Painful Recollection subscale.

Psychosocial correlates of the CzSVPGS

Janssen et al. (1997) and Lasker and Toedter (1991) proved that the intensity of grief decreases during years following the perinatal loss (Toedter et al., 2001, p. 218). That is why we expected that the level of grief in women (CzSVPGS score) would decrease with time elapsed from the perinatal loss. We discovered a statistically significant trend ($p < 0.001$) in the levels of grief (CzSVPGS score) depending on time elapsed from the perinatal loss consistent with this hypothesis. The more time elapsed from the event the lower the level of grief.

Toedter et al. (2001) stated that people with high SVPGS scores (above 91) could be particularly vulnerable because of the loss. We hypothesized that women who sought psychiatric help during the grieving process displayed higher levels of grief (CzSVPGS score) than other women. We discovered a statistically significant difference in the perceived grief between women who sought a psychiatrist and those who did not. The levels of grief (CzSVPGS score) were statistically significantly ($p = 0.0006$) higher in women who had to see a psychiatrist.

Discussion

Our results are another example of the problematic comparison of the SVPGS' inner structure across cultures. Studies by Toedter et al. (1988, 1989) presented a consistent inner pattern or structure. But our study from the Czech Republic shows that in this culture, the inner structure is different. Could this be due to translation or application? Possibly yes. But the CzSVPGS was translated according to the highest standards and another two respected studies (Capitulo et al., 2010; Yan et al., 2010) show a different inner

structure as well. Both of them differ from each other and also from our study. Such differences show that items are comprehended differently in each culture. The first basket of studies (in Toedter et al., 2001) operated mainly in the cultural area of Western Europe and USA (white parents). But studies from China, Eastern Europe or the Latino community in New York City gave different results. Although bereavement can be a universal experience, its representation and influence on the life of an individual are modified by her personality, culture and society.

The average total score of the SVPGS with Czech women (mean = 88.8) is slightly higher compared to the values from research originated in Western European countries in women after late pregnancy loss, but slightly lower compared to the SVPGS values from US samples recruited from support groups and Internet sources (see Table 5).

Table 5 Comparison of the Czech results with those reported by Toedter et al. (2001, p. 216) – selected data: female participants, late loss, Europe, USA

SVPGS	M	SD	SEM	M+2 (SEM)
Czech Republic	88.8	27.7	2.77	94.3
USA	90.4	16.96	4.55	99.5
Female	86.00	18.36	4.60	95.2
Late Loss	84.00	14.49	4.19	92.4
Europe	75.00	8.56	2.47	80.0

The results of our research show great cultural differences connected with rituals after perinatal loss. While the present study suggests that only 41.4% of Czech women saw their baby after stillbirth (after 22nd gestational week) or an early newborn death, 90-95% of women in the Western countries did (Cacciatore et al., 2008; Erlandsson et al., 2013). According to a study by Capitulo et al. (2010, p. 129), 66.7% of Hispanic parents saw their dead baby. It is also very common in Western countries that the parents get a memento of their dead baby from the hospital (photograph, handprint/footprint, or a lock of hair). In the Czech Republic, only 24.1% of parents own a memento of their late children. The care for parents after perinatal loss is still influenced by the previous political regime, the process of healthcare humanization is slow and the paternalistic approach of the healthcare professionals is still dominant. We expect that the way society treats perinatal loss and approaches parents influences the way bereaved parents experience their situation, perceive it and grieve. That could be the reason why the SVPGS scale that has excellent internal consistency reliability as well as construct and convergent validity in the Western countries does not have the same inner

structure in the Czech Republic. Our research points to the necessity to focus efforts towards testing comparability of the SVPGS in different cultures.

When interpreting the results of our study we should keep in mind the limitations caused by the method of choosing the research sample and the low number of participants. Some limitations were caused by our decision to address women after perinatal loss via a self-help group and internet discussion group. Firstly, participants from support groups and self-selected participants usually consider the loss of their baby as more troubling and more salient in their lives than women from medical sources, which was confirmed by Toedter et al. (2001, p. 220). Secondly, the sample selection was limited to women who had internet access. The survey was accessible mainly via direct emails to women in the self-help group, but we cannot be completely sure that the questionnaire was not abused by a person who did not experience perinatal loss. Last but not least, the results may be influenced by the low number of participants.

Conclusion

We discovered that the CzSVPGS may be used as a single factor scale while maintaining all of the elements of the original scale. The reliability of this research tool as determined by Cronbach's alpha coefficient ($\alpha = 0.9545$) was high. The CzSVPGS construct validity was assessed using factor analysis and proven by the relationship between the measured values and variables (time, psychiatric morbidity).

The CzSVPGS may be utilized to identify women that tend to be more vulnerable after perinatal loss than others. It can be also used to create an international comparison between grief scores or to assess healthcare efficiency with women after perinatal loss. The tool might identify women that experience an extremely high intensity of grief so that they can be offered consultations or support from medical and social systems.

Any similar instruments are still missing in the Czech Republic. We think that its use in clinical practice is justified and recommend using it in midwifery as well as consultations for the bereaved, psychological counselling or by psychiatrists working with women after perinatal loss. Midwives could routinely use the CzSVPGS when assessing women after perinatal loss in the puerperium to objectivize their intensity of grief, provide personalized support or education, and to avoid potential complications in the grieving process and recommended professional psychological help. Considering the results of our study, we will strive for additional research in the perinatal grief area with the aid of the CzSVPGS.

Ethical aspects and conflict of interest

Respondents of our study were openly informed about the goal of the research and investigators and the fact that the questionnaires would be analyzed and presented anonymously. The basic ethical aspects of research were adhered to. All respondents consented to their participation.

The authors of the original Perinatal Grief Scale were contacted in writing and agreed in writing with its translation, validation and use in research in the Czech Republic.

The authors found no conflict of interest that would threaten the fundamental publication principles.

Author contribution

Concept and design (KR, FK), analysis and data interpretation (FK, KR, JB), draft report preparation (KR, FK), critical review (JB), study report finalization (KR).

References

- Adolfsson A. Meta-analysis to obtain a scale of psychological reaction after perinatal loss: focus on miscarriage. *Psychology Research and Behavior Management*. 2011;4:29–39.
- Adolfsson A, Larsson PG. Cumulative incidence of previous spontaneous abortion in Sweden in 1993-2003. A register study. *Acta Obstetrica et Gynecologica Scandinavica*. 2006;85(6):741–747.
- Beutel M, Deckart R, Schaudig K, Franke S, Zauner R. Trauer, Depressivität und Angst nach einem Spontanabort – Eine Studie über systematische Erfassung und Einflussfaktoren. *Psychotherapie Psychosomatik Medizinische Psychologie*. 1992;42:158–166. (in German)
- Beutel M, Will H, Volkl K, von Rad M, Wiener H. Erfassung von Trauer am Beispiel des Verlustes einer Schwangerschaft: Entwicklung und erste Ergebnisse zur Validität der Münchner Trauerskala. *Psychotherapie Psychosomatik Medizinische Psychologie*. 1995;45:295–302. (in German)
- Cacciatore J, Radestad I, Froen F. Effects of contact with stillborn babies on maternal anxiety and depression. *Birth*. 2008;35(4):313–320.
- Capitulo KL, Cornelio MA, Lenz ER. Translating the short version of the Perinatal grief scale: process and challenges. *Applied Nursing Research*. 2001;14(3):165–170.
- Capitulo KL, Ramirez M, Grigoroff-Aponte B, Vahey, DC. Psychometric testing of the new Spanish short version of the Perinatal grief scale to measure perinatal grief in spanish-speaking parents. *Hispanic Health Care International*. 2010;8(3):125–135.
- Clauss DK. *Psychological distress following miscarriage and stillbirth: an examination of grief, depression and anxiety in relation to gestational length, women's attributions, perception of care and provision of information*. Doctoral Thesis. Drexel University; 2009.
- Erlandsson K, Warland J, Cacciatore J, Radestad I. Seeing and holding a stillborn baby: Mothers' feelings in relation to how their babies were presented to them after birth – Findings

- from an online questionnaire. *Midwifery*. 2013;29(3):246–250.
- Hollins Martin C, Forrest E. *Bereavement care for childbearing women and their families: An interactive workbook*. 1st ed. Routledge; 2013.
- Hutti MH, DePacheco M, Smith M. A study of miscarriage: development and validation of the Perinatal grief intensity scale. *Journal of Obstetric, Gynecologic and Neonatal Nursing*. 1998; 27(5):547–555.
- Lasker NJ, Toedter L. Satisfaction with hospital care and interventions after pregnancy loss. *Death Studies*. 1994;18(1):41–64.
- Murray JA, Terry DJ, Vance JC, Battistutta D, Connolly Y. Effects of a program of intervention on parental distress following infant death. *Death Studies*. 2000;24(4):275–305.
- Neimeyer RA, Hogan NS, Laurie A. The measurement of grief: Psychometric considerations in the assessment of reactions to bereavement. In: Stroebe MS, Hansson RO, Stroebe W, Schut H, editors. *Handbook of bereavement research and practice: Advances in theory and intervention*. Washington, DC: American Psychological Association; 2008. p. 133–161.
- Potvin L, Lasker NJ, Toedter L. Measuring grief: A short version of the Perinatal grief scale. *Journal of Psychopathology and Behavioral Assessment*. 1989;11(1):29–45.
- Ritsher JB, Neugebauer R. Perinatal bereavement grief scale. Distinguishing grief from depression following miscarriage. *Assessment*. 2002;9(1):31–40.
- StataCorp. *Stata/SE 12.1 for Windows*. College Station: StataCorp LP; 2013.
- Stroebe MS, Hansson RO, Stroebe W, Schut H. *Handbook of bereavement research and practice: Advances in theory and intervention*. Washington, DC: American Psychological Association; 2008.
- Štembera Z, Velebil P. Vývoj perinatální úmrtnosti v ČR. *Interní medicína pro praxi*. 2003;5(3):21–25. (in Czech)
- The Czech Statistical Office. *Mother and Newborn 2011*. Prague: ÚZIS ČR. 2012.
- The Czech Statistical Office. *Mother and Newborn 2012*. Prague: ÚZIS ČR. 2013.
- Theut SK, Pedersen FA, Zaslow MJ, Cain RL. Perinatal loss and parental bereavement. *The American journal of psychiatry*. 1989;146(5):635–639.
- Toedter L, Lasker NJ, Alhadeff JM. The Perinatal grief scale: Development and initial validation. *American Journal of Orthopsychiatry*. 1988;58(3):435–449.
- Toedter L, Lasker NJ, Janssen HJEM. International comparison of studies using the Perinatal grief scale: A decade of research on pregnancy loss. *Death Studies*. 2001;25(3):205–228.
- Yan E, Tang CS, Chung T. Validation of the Perinatal grief scale for use in Chinese women who have experienced recent reproductive loss. *Death Studies*. 2010;34(2):151–171.